

A77 system

The A77 is smart & slim design, durable pedestal. the high quality plastic frame combined make it a perfect solution for retail market.

The pedestal delivering superior pick rates in all environments, even noisy ones.

The coverage area is 0.9m (3 ft) for a single door and 1.8m (6 ft) for Dual Pedestal The integrated alarm located in the base of the primary pedestal uses a distinguished audible alarm to notify store personnel if protected merchandise passes through the detection zone and also illuminates red for visual notification.

Key Features

- Smart & Slim Design
- Cost effective
- Wider exit & Maximizing customer flow
- Strong noise immunity in complicated installation environment
- Robust
- Expandable future functions
- Integrated alarm statistic
- Easy and intelligent tuning with lap-top computer
- Protecting full range of items in all kind of stores
- Easy synchronization with competitor's AM system in surrounding area



Specifications

Transmitter

Operation
Frequency.....58kHz

Transmit Burst
Duration.....1.6ms

Max Transmit
Current16A
peak

Receiver

Centre
Frequency 58kHz

Mechanical

Height 1550mm

Width 420mm

Thickness ... 25mm

Weight 16kg

Material Flame
retardant ABS engineering
plastic

Colour Grey Black

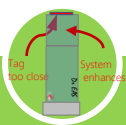

Our Corelite A77 System Performance Analysis with Malaysia Retailer reference

Company	Corelite	Other Competitor
Model	A77	AM System
Technology	58kHz	58kHz
Width of between pedestal	5.5 – 6ft	5 – 5.6ft
Susceptible to electric noise	Yes	NO
Susceptible to lighting interference	Yes	NO
Susceptible to Environment noise	Yes	Depends (tune down sensitive avoid false alarm)
Accurate detection of label (base on maximum distance)	92 – 95% (6ft)	90% (5.5 ft)
Metal Foil Detection	Yes 85 - 90%	Yes 80 – 82%



The A77 system operation can enhance electrical noise, lighting Interference, or etc...

- We are EAS Local ownership
- This A77 system suitable in Malaysia Retail Market
- Flexible and Customized
- Standalone operating System

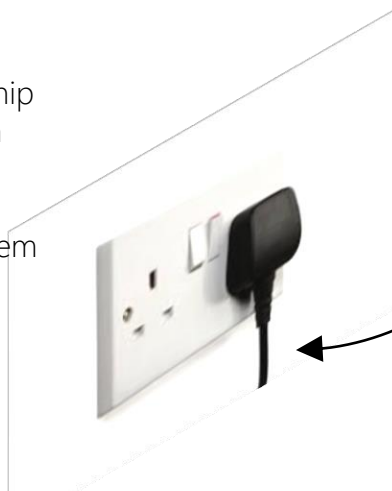

- RF test report EN 300 330
- SIRIM approval : RALI/01D/1217/S(17-3895)

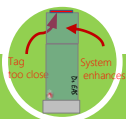

A77 Pedestal wiring

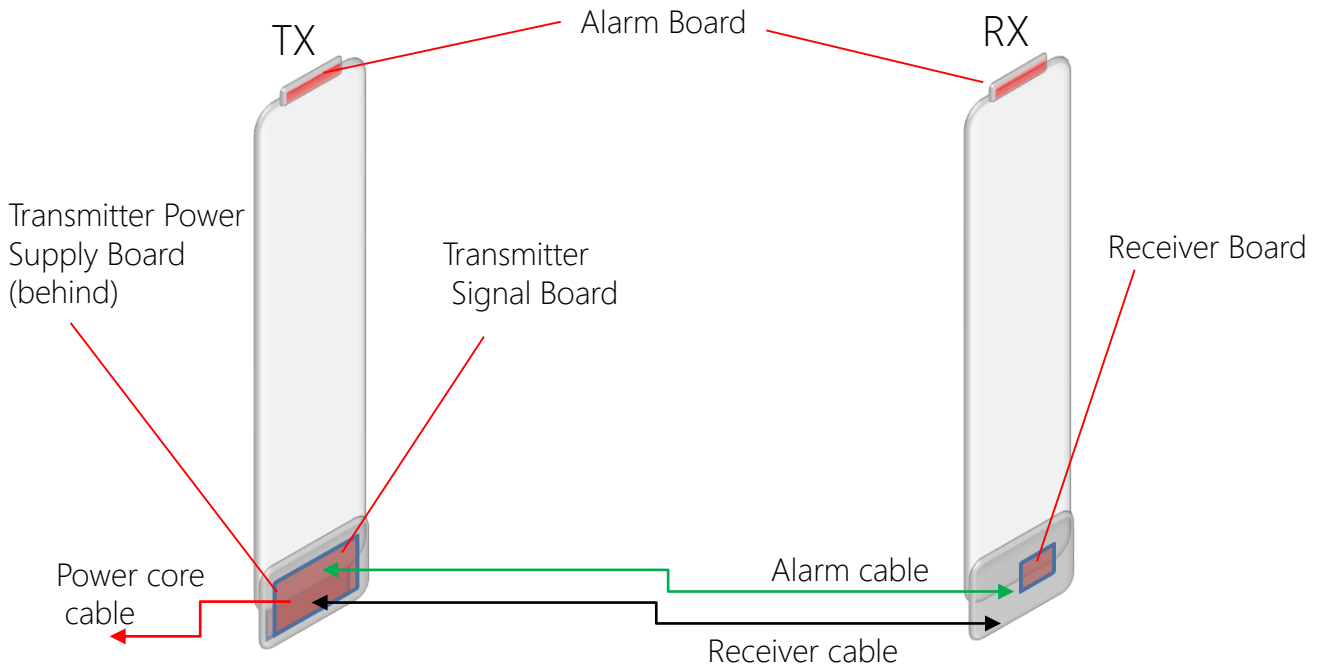

Component or Part List

Transmitter Pedestal

Transmitter pedestal A77-9000-01

Transmitter Power Supply Board	77-9000-01
Transmitter Signal Board	77-9001-01
Alarm Board	77-9003-01

Receiver Pedestal

Receiver pedestal A77-9002-01

Receiver Board	77-9002-01
----------------	------------

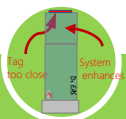

Specifications

Electrical

Power Supply (Switched Mode Transmitter)

Primary Input 100-120Vac or
220-240Vac @ 50-60Hz

Primary Power Fuse2.5A, 250V

Current Draw2.0A peak

Input Power <180W

Transmitter (Switched Mode Transmitter)

Operating Frequency 58kHz (± 200 Hz)

Transmit Burst Duration..... 1.6ms

Transmit Current 16A peak

Receiver

Center Frequency 58kHz

Receive Coil Resistance 1.6 ohms ($\pm 5\%$)

Environmental

Operating Temperature 0° to 30°C
(32° to 86°F)

Mechanical

Transmitter Pedestal

Height 1550mm (61in)

Width 420mm (16.5in)

Depth63.5mm (2.5 in)

Depth (base)145mm (5.7in)

Weight 16kg (35.2 lb)

Secondary Pedestal

Height 1550mm (61in)

Width 420mm (16.5in)

Depth63.5mm (2.5 in)

Depth (base)145mm (5.7in)

Weight 10.5kg (22.5 lb)

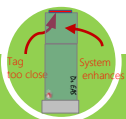
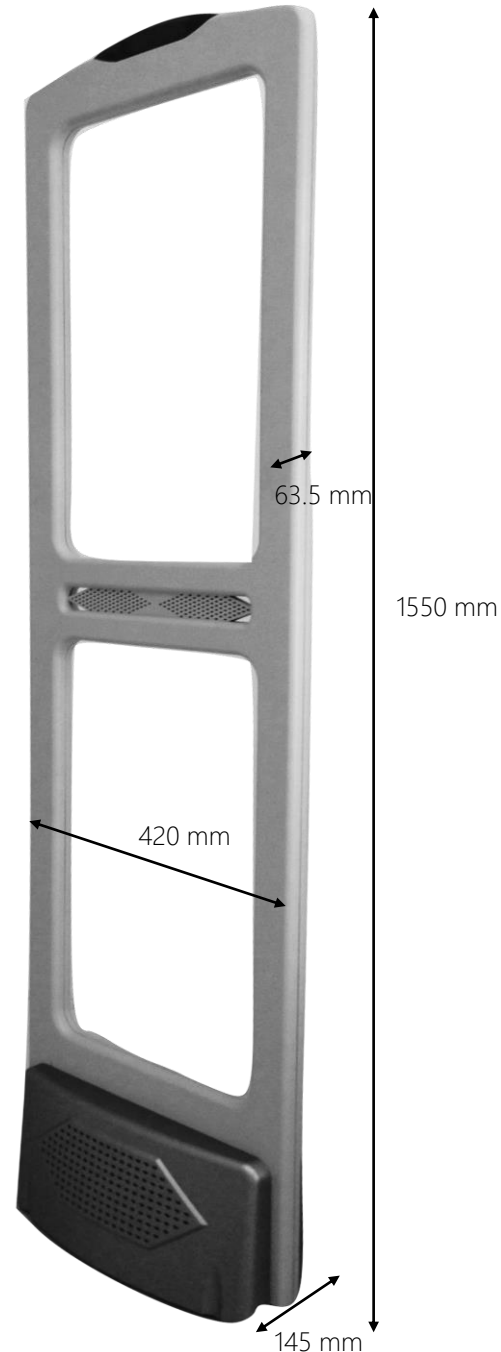



KOD SYARIKAT C00611
Company Code (SQASI/TA/17/3895)

NO. SIRI : E 083871
Serial No.

NAMA SYARIKAT
Company Name

: CORELITE SDN BHD (973259-D)

ALAMAT
Address

: 1-9A, KOMPLEKS PERNIAGAAN SELAYANG POINT JALAN SP 1
68100, BATU CAVES,
SELANGOR DARUL EHSAN

NO. KELULUSAN
Approval No.

: RALI/01D/1217/S(17-3895)

KATEGORI ALAT
Device Category

: RADIO FREQUENCY IDENTIFICATION DEVICE (RFID)

PIAWAIAN
Standards

: MCMC MTSFB TC T007:2014

JENAMA
Brand

: CORELITE

MODEL
Model

: A77 [Frequency: 58kHz]

**TARIKH
KELULUSAN**
Approval Date

: 06 December 2017

TARIKH LUPUT
Expiry Date

: 21 July 2024

**TARIKH
DIKELUARKAN**
Issuance Date

: 22 July 2019

Note :

Certification of Communication, Multimedia and Hybrid Equipment (Equipment) means that the product has met the requirements of the above standards. The certification of the equipment does not in itself confer a right on the certificate holder to operates the equipment.



Mohd Azanuddin bin Salleh

Chief Executive Officer
SIRIM QAS International



TEST REPORT

ETSI EN 300 330 V2.1.1: 2017-02

Report Reference No......: HTT171113011E

Compiled by

(position+printed name+signature)..: Jack Chen

Jack Chen

Supervised by

(position+printed name+signature)..: Owen Hu

Owen Hu

Approved by

(position+printed name+signature)..: Kevin Yang

Kevin Yang

Date of issue.....: Nov,06,2017

Testing Laboratory Name: Shenzhen HTT Technology Co., Ltd.

Address: 7F,A Building,Smart valley Science and technology innovation Park,Xixiang,Baoan District,Shenzhen,Guangdong,China

Applicant's name.....: SHENZHEN ENGUARD DIGITAL CO.,LTD.

Address: Chao loft Cultural Creative Park,Huayue Road No. 150 , Dalang Street, Longhua New Dist., Shenzhen, Guangdong, China

Test specification

Standard: ETSI EN 300 330 V2.1.1: 2017-02

Shenzhen HTT Technology Co., Ltd. All rights reserved.

This publication may be reproduced in whole or in part for non-commercial purposes as long as the Shenzhen HTT Technology Co., Ltd. is acknowledged as copyright owner and source of the material. Shenzhen HTT Technology Co., Ltd. takes no responsibility for and will not assume liability for damages resulting from the reader's interpretation of the reproduced material due to its placement and context.

Test item description

Trade Mark: N/A

Manufacturer: SHENZHEN ENGUARD DIGITAL CO.,LTD.
Chao loft Cultural Creative Park,Huayue Road No. 150 ,
Dalang Street, Longhua New Dist., Shenzhen, Guangdong,
China

Model/Type reference.....: Corelite A77(Plastic)

Serial Model.....: Corelite A66(Arcylic),Corelite A55B (Beta floor loop system)

Ratings: AC 230V/50Hz

Result.....: **PASS**





Report No.: HTT171113011E

Page 2 of 19

TEST REPORT

Test Report No. :	HTT171012269E-2	Nov.06,2017
		Date of issue

Equipment under Test : Eas anti-theft system

Model Name : Corelite A77(Plastic)

Serial Model : Corelite A66(Arcylic),Corelite A55B (Beta floor loop system)

Trade Mark : N/A

Applicant : SHENZHEN ENGUARD DIGITAL CO.,LTD
: Chao loft Cultural Creative Park,Huayue Road No. 150 ,
Address : Dalang Street, Longhua New Dist., Shenzhen, Guangdong,
China

Manufacturer : SHENZHEN ENGUARD DIGITAL CO.,LTD
: Chao loft Cultural Creative Park,Huayue Road No. 150 ,
Address : Dalang Street, Longhua New Dist., Shenzhen, Guangdong,
China

Test Result:	PASS
---------------------	-------------

The test report merely corresponds to the test sample.
It is not permitted to copy extracts of these test result without the written permission of the test laboratory.

CORELITE - Customer References

